



Testing Methods for Electronic Watches

Witschi Electronic AG, 2025

Table of contents

Table of contents	2
Basics	3
Types of electronic movements	3
Components of a quartz watch	3
Analogue quartz watch	12
Integrated Circuit (IC).....	17
Digital quartz watch	22
Rate calibration	24
Measurements and tests	28
Battery voltage	28
Current recording	29
Minimum operating voltage	30
Rate deviation	31
Rate deviation quartz	32
Pulse duration	32
Power level.....	33
Shape of the motor pulse	34
Resistance measurement	35
Accelerated mode.....	37
Pulse generator	37
Testing of closed quartz watches	39
Testing of opened quartz watches	40
Test procedure	40
Troubleshooting	41
Overview Witschi measuring devices for quartz watches	43

Basics

Types of electronic movements

Electronic movements allow time to be measured either partially or entirely by electronic means. They were primarily developed to reduce rate deviation compared to mechanical movements.

Watch types

Initial designs used a mechanical balance wheel with permanent magnets, electromagnetically coupled to a sustaining circuit. This allowed the balance wheel to oscillate with minimal disturbance, while still serving as the primary timekeeping element.

Later, the balance was replaced by a magnetically driven **tuning fork**, which was used in tuning fork watches. The vibration of the tuning fork was transmitted mechanically to the gear train via a pawl mechanism.

However, the tuning fork was soon replaced by a **quartz oscillator**. This also has the shape of a tuning fork but is in a hermetically sealed housing. The excitation is purely electrical. The quartz oscillator ultimately prevailed, and modern electronic watches are now almost exclusively based on quartz technology.

In some cases, quartz crystals are supplemented by other systems to minimise the rate deviation over longer periods of time (days to years). Such systems enable synchronisation with time signals such as DCF77, GPS signals, the mobile phone network or time signals from the Internet. Direct synchronisation with atomic clocks has so far only been implemented in prototypes of wristwatches.

This document focuses exclusively on quartz watches without external synchronisation. A distinction is made between **analogue quartz watches** (with hands) and **digital quartz watches** (with LCD display).

While LCDs remain standard due to their low energy consumption, LED displays are also used in specific applications and are available again in small production quantities.

Components of a quartz watch

An **analogue quartz watch** consists of several components:

- a **battery** as the power source
- an **integrated circuit** (IC), acting as frequency divider and motor driver
- a **quartz crystal** as the time base
- a **stepper motor** to drive the hands
- a **gear train** that transmits the movement to the second, minute and hour hands

A **digital quartz watch** contains

- a **battery** for the power supply
- an **integrated circuit** (IC) as a counter and driver for the display
- a **quartz crystal** as the timebase
- a **liquid crystal display** (LCD) or **light emitting diode** (LED) to show the time

This section provides a more detailed description of the components common to both types of watches — the battery and the quartz crystal.

Battery

The battery provides the energy required to operate the quartz watch. Depending on the power requirements of the movement, it can run for several years.

Batteries should only be handled with insulated tweezers or gloves to avoid short circuits and contamination.

Most watches use silver oxide button cells (Ag₂O-Zn) with a nominal voltage of 1.55 V.

However, modern electronic watches often include additional features, which increase their energy requirements. In this case, high-drain or multi-drain silver oxide batteries are able to meet the higher current demands or lithium batteries with a higher capacity, a higher nominal voltage (3 V), a lower self-discharge rate and a higher temperature range are used.

Three button battery types commonly used in watches:

Type	Nominal voltage	Electrolyte	Typical Application
Silver oxide (low drain)	1.55 V	Sodium hydroxide (NaOH)	Watches without backlight or alarm
Silver oxide (high drain)	1.55 V	Potassium hydroxide (KOH)	Watches with backlight or alarm
Lithium manganese dioxide	3.0 V		Watches with higher energy requirements

The NIHS 13-02 standard specifies the designation, labelling, and testing criteria for watch batteries. It is based on the international standards IEC 60086-1 and IEC 60086-2, which define the general requirements and performance characteristics of primary batteries.

Examples of battery prefixes:

- SR - Silver oxide
- CR - Lithium manganese dioxide
- BR - Lithium poly-carbon monofluoride
- LR - Alkaline manganese

Example of a battery designation: SR516SW

- S = silver oxide
- R = Round cell (button cell)
- 5 = Diameter code (5.8 mm)
- 16 = Height code (1.6 mm)
- SW = Low-drain (low power consumption)

A battery consists of two electrodes, the **cathode (+)** and the **anode (-)**, which are separated by an **electrolyte**. Other components such as the separator, seal, housing and cover are not involved in the chemical reaction but ensure safety and stability.



Figure 1: Structure of a watch battery

Part number	Component	Function
1	Housing	Positive pole (+). Protects the internal components and ensures stability. The external nickel coating protects against corrosion and ensures good electrical contact.
2	Cathode (+)	Positive electrode (Ag_2O) at which the reduction takes place.
3	Pressure ring	Ensures mechanical stability and pressure equalisation (depending on battery type).
4	Separator	Separates anode and cathode, prevents short circuits, enables ion exchange.
5	Gasket	Prevents electrolyte leakage and protects against environmental influences.
6	Electrolytes	Enables the transport of ions between cathode and anode.
7	Anode (-)	Negative electrode (Zn) at which oxidation takes place.
8	Lid	Closes the battery and serves as a contact surface, negative pole (-).

The separator reduces self-discharge but increases the internal resistance of the battery. As a result, the voltage may be lower under load. However, the measured voltage does not provide a reliable indication of the remaining capacity.

The **nominal voltage** of a battery depends on its overall design — particularly the active materials (zinc and silver oxide), the separator, the electrolyte, and the housing.

The **capacity**, on the other hand, is mainly determined by the amount of active materials, i.e. the amount of zinc and silver oxide that the manufacturer has placed in the battery. It is specified in milliampere hours (mAh) and typically defined as the discharge capacity down to a cut-off voltage of 1.2 V.

A battery with a higher capacity ensures a longer service life for the watch.

The **theoretical battery life** can be calculated by dividing the nominal capacity (in mAh) by the average current consumption of the movement (in μA or mA).

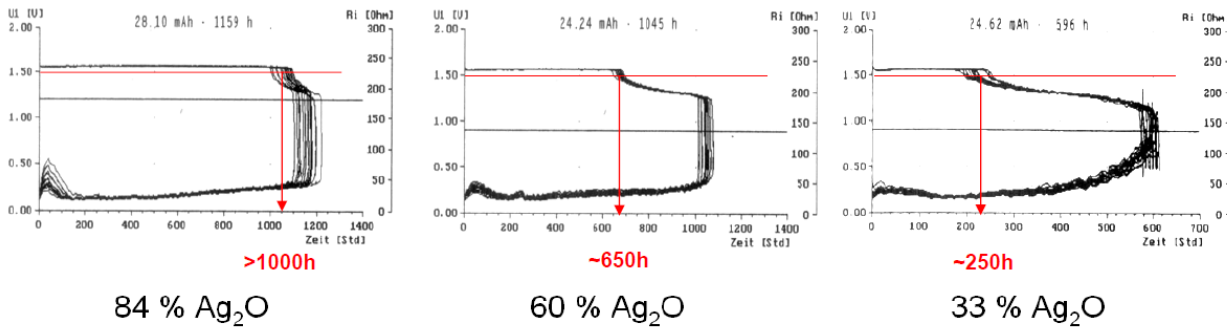

Figure 2: Discharge curves as a function of the silver content.

Low-drain and high-drain

High-drain batteries are used in watches with functions that require a lot of power for a short period of time - such as backlighting or an acoustic alarm signal. These batteries are characterised by a lower internal resistance, which means they can supply the required current without a significant voltage drop.

However, one disadvantage of high-drain batteries is their shorter storage time and higher self-discharge, which can reduce their overall service life.

Difference between High Drain and Low Drain Batteries

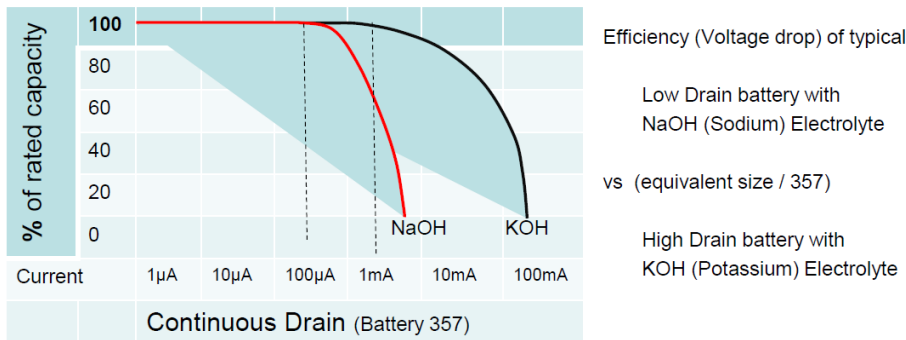

Figure 3: Capacity as a function of the discharge current for low and high drain batteries.

Storage

Batteries should be stored in their original packaging, in a dry place and at temperatures between 10°C and 25°C. The temperature must never exceed 30°C, as higher temperatures accelerate self-discharge and shorten the service life.

If batteries are exposed to moisture, the resistance between the terminals decreases, which can lead to increased self-discharge. Moisture can also cause corrosion.

Batteries have a limited storage time as their capacity decreases over time due to self-discharge. According to the 2014 ISO recommendation, the production code usually contains the month and year of manufacture in order to be able to trace the remaining shelf life.

Example of the manufacturer code for batteries from Maxell, Seiko, Sony and Renata.

2-digit code:

- 1st digit = year
- 2nd digit = month (1-9 = Jan.-Sept., O = Oct., Y = Nov., Z = Dec.)
- Example: "3Z" = December 2023

4-digit code:

- Last 2 digits = production batch
- First 2 digits = Year/month depending on manufacturer
- Example: "2312" → Production batch 12, year possibly 2023

The manufacturer specifies a **maximum storage period for batteries**:

- Low-drain batteries: up to 3 years
- High-drain batteries: up to 2 years

After this time, **self-discharge** can reduce the capacity, which impairs the performance of the watch.

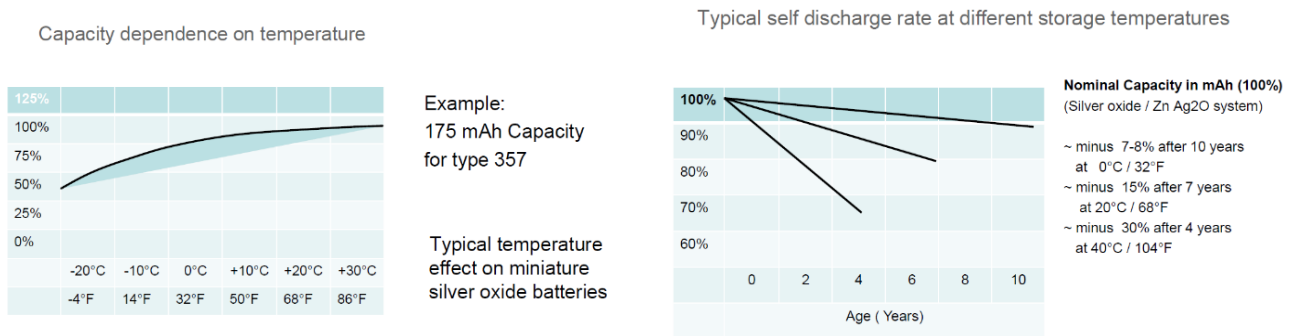

Figure 4: Left: Temperature dependence of the capacity.

Right: Remaining capacity during storage.

After the power supply via the battery, the watch quartz forms the central element for the time control of the watch.

Watch quartz

A **watch quartz** serves as the **time base** of the watch, with the rate stability depending directly on its frequency accuracy.

When an electrical voltage is applied, the crystal begins to oscillate, a phenomenon known as the **inverse piezoelectric effect**.

Watch crystals are typically shaped like a tuning fork and are hermetically sealed in a metal housing to protect them from environmental influences.

The standard oscillation frequency is **32,768 Hz**, significantly higher than that of a mechanical watch.

Thanks to its high **quality factor (Q)**, the quartz provides excellent frequency stability, which enables high timekeeping accuracy.

Factors affecting the **frequency stability of a watch quartz**:

- Temperature
- Air humidity
- Ageing
- Load
- Supply voltage

Potential causes of quartz failure, for example

- Acceleration
- Mechanical shock
- Vibration

The influence of electric and magnetic fields on the quartz frequency, on the other hand, is negligible.

Accuracy

The **accuracy of the quartz crystal frequency** directly determines the **timekeeping precision** of the watch. Frequency deviation is typically expressed in **parts per million (ppm)**.

The resulting rate deviation of the watch is usually specified in either **seconds per day (s/d)** or **seconds per month (s/m)**, depending on the level of precision.

ppm	s/d	s/M
0.1157	0.0100	0.300
0.3858	0.0333	1.000
1.0000	0.0864	2.592
1.1574	0.1000	3.000
11.574	1.0000	30.000

Table1: Conversion of units for measuring frequency and rate deviations.

Typical values for rate deviations due to various influences on a watch quartz are given in the following table.

Reason	ppm	s/d
Frequency deviation after production	±20	±1.73
Stray capacitance within the IC	±10	±0.86
Printed circuit board (stray capacitance)	±1	±0.08
Total for adjustment [1]	±31	±2.67

Reason	ppm	s/d
Temperature dependence	0.038 / °C ²	0.0033 / °C ²
Ageing in the first year	±3	±0.26
Impacts (5 to 10 kg / 0.3ms)	±5	±0.43
Vibration (20g / 20 - 20kHz / 20 min)	±3	±0.26

[1] This value is measured during production and corrected during adjustment.

Table2 : Typical rate deviation for watch quartz.

Capacitive load

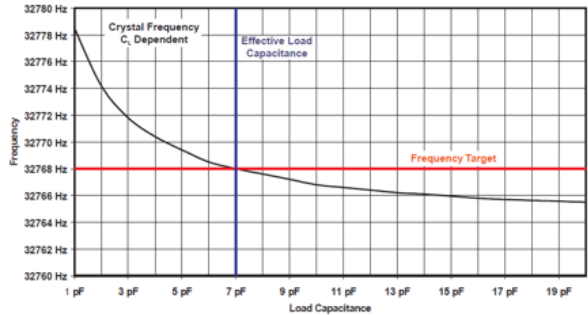
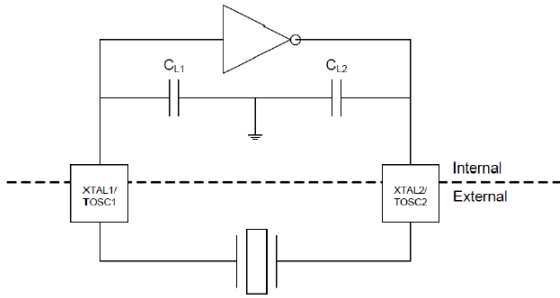

The oscillation frequency of the quartz crystal is influenced by the capacitive load applied to it. A typical curve of the oscillation frequency as a function of the capacitive load is shown in Figure5. In watches using inhibition adjustment, the frequency is deliberately set slightly above 32,768 Hz by selecting a smaller capacitive load.

Figure 5: Left: Block diagram of the oscillator. Right: Frequency as a function of the capacitive load.

Ageing

Ageing of the quartz leads to structural defects within the crystal lattice, resulting in a gradual shift of its resonance frequency. This change typically follows a logarithmic trend, meaning that newer quartz crystals are more affected than older ones.

The maximum frequency deviation due to ageing is specified by the manufacturer. Typically, it is around ±10 ppm over 10 years, although the actual values are often lower. However, the ageing behaviour of individual quartz units cannot be precisely predicted.

Although ageing may cause the frequency to increase or decrease, in more than 90% of cases a decrease is observed.

Temperature influence

The frequency of a quartz crystal is affected by temperature. For quartz cuts typically used in watches, the frequency variation follows a parabolic curve.

To minimise the influence of temperature on the frequency, quartz blanks are cut in such a way that the turning point of this curve lies around 25 °C, which corresponds approximately to the average skin temperature when worn on the wrist.

The parabolic dependency is described mathematically as

$$\frac{F_{xT} - F_0}{F_0} = \frac{\Delta F_{xT}}{F_0} = \beta(T - T_{inv})^2$$

whereby

T_{inv} Temperature at the Turning point ($25^{\circ}\text{C} \pm 5^{\circ}\text{C}$)

F_{xT} Frequency at temperature T

F_0 Frequency at the turning point temperature T_{inv} (typ. 32'768 Hz at 25°C)

β Coefficient of frequency dependence (typ. $-(0.035 \pm 0.005) \text{ ppm}/^{\circ}\text{C}^2$)

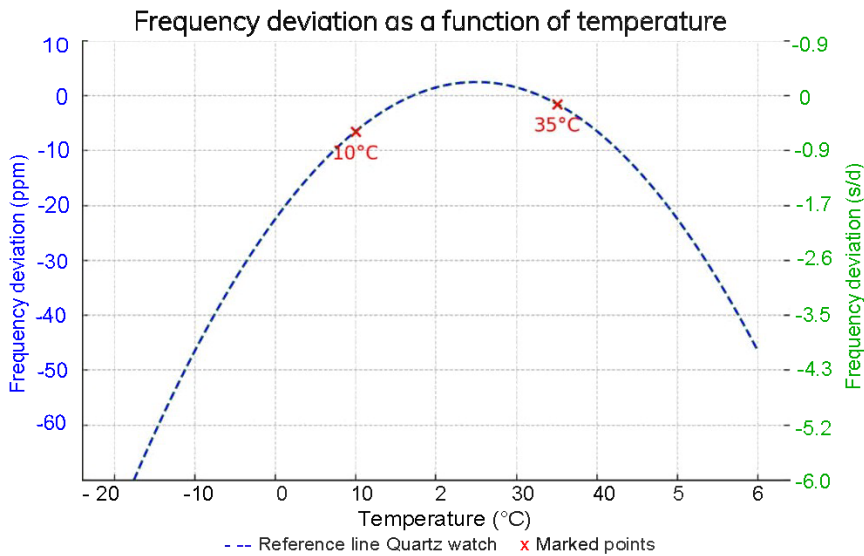

Figure 6: Frequency deviation as a function of temperature for watch quartz

Example of frequency deviation at $T = 10^{\circ}\text{C}$

$$\frac{\Delta F}{F_0} = \beta(T - T_{inv})^2 = 0.038(10 - 25)^2 = 8.55 \text{ ppm} \rightarrow 0.74 \text{ s/d}$$

Example of frequency deviation at $T = 35^{\circ}\text{C}$, which corresponds to a possible temperature within a watch on the wrist.

$$\frac{\Delta F}{F_0} = \beta(T - T_{inv})^2 = 0.038(35 - 25)^2 = 3.8 \text{ ppm} \rightarrow 0.33 \text{ s/d}$$

Since the temperature of a watch worn on the wrist is usually slightly above room temperature, a slight rate gain of +0.1 s/d to +0.2 s/d is often aimed for when calibrating.

Thermocompensation

As previously mentioned, the oscillation frequency of a watch quartz is temperature dependent. **Thermocompensated quartz crystals** are equipped with an integrated temperature-sensing circuit that continuously adjusts the frequency to compensate for temperature-induced deviations.

To enable thermal compensation, the oscillation frequency of each crystal is characterised during production as a function of temperature. The resulting curve is approximated using a polynomial function.

During operation, the circuit measures the internal temperature of the thermocompensated quartz crystal and calculates the necessary correction. The frequency is then adjusted, for example via **varactor diodes** (voltage-controlled capacitors), whose capacitance varies with the applied control voltage. This makes it possible to adapt the capacitive load of the crystal and thus stabilise its oscillation frequency.

Figure 7 illustrates the effectiveness of thermal compensation, comparing the frequency deviation **before (blue)** and **after (red)** compensation.

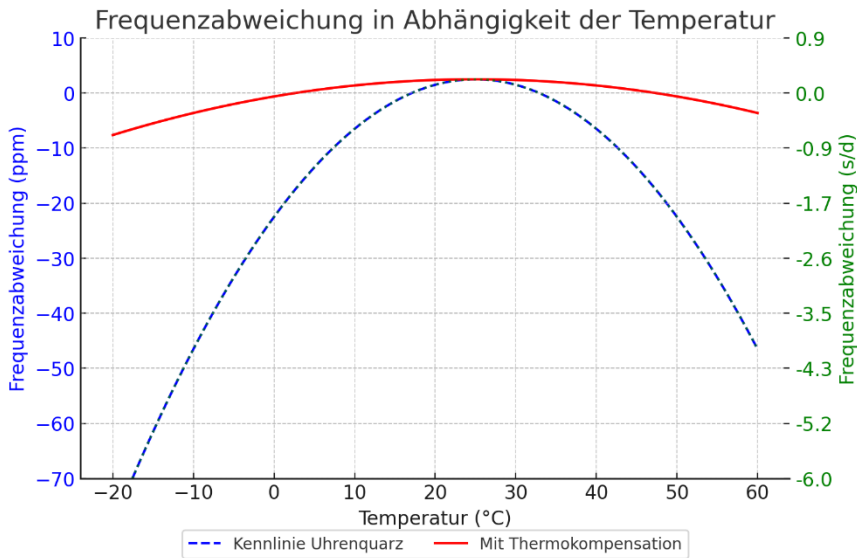

Figure 7: Frequency deviation as a function of temperature with thermocompensated quartz.

To accurately measure the rate of a thermocompensated quartz watch, the measurement duration should span at least one full thermal compensation cycle.

These periods are specified in the watch's data sheet and are typically 4, 8 or 16 minutes. A measurement period that is too short can lead to inaccurate results, as the complete thermal compensation cycle is not recorded.

Thanks to thermal compensation, very high accuracy can already be achieved. However, additional requirements apply for particularly precise timepieces - as must be met by quartz chronometers.

Quartz chronometers

The **Contrôle Officiel Suisse des Chronomètres (COSC)** has developed its own test standard for quartz chronometers, which comprises eight exclusion criteria (see table below).

COSC test criteria for quartz chronometers

Symbol	Criterion	Limit value (s/d)
Avg R	Mean daily rate at 23°C	±0.07
M _{T8}	Rate at 8°C	± 0.20
M _{T38}	Rate at 38°C	±0.20
SM	Rate stability	0.05
D	Dynamic rate	±0.05
TE	Temporary effect of mechanical shocks	±0.05
R	Rate Resumption	±0.05
RE	Residual effect of mechanical shocks	±0.05

Analogue quartz watch

As already mentioned, an analogue quartz watch consists of a battery, an IC as a counter and motor driver, a quartz oscillator, an electric motor to drive the hands and a gear train that drives the second, minute and hour hands.

This chapter provides a detailed explanation of the **specific components of the analogue quartz watch**. These include

- **The IC with motor driver** controls the time base and powers the motor.
- **The electric motor** converts the electrical impulses into mechanical movement.
- **The gear train** transmits the rotation of the motor to the hands of the watch.

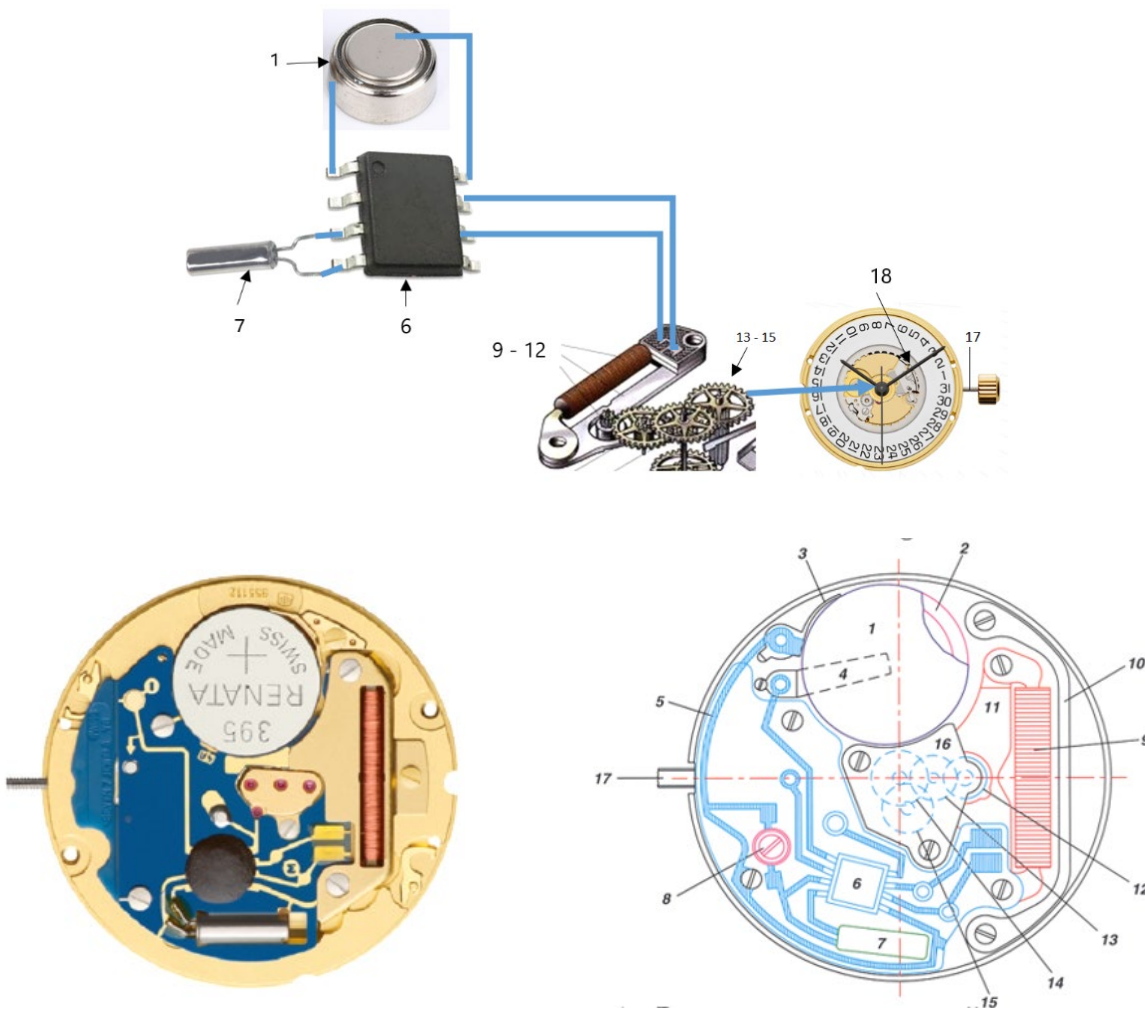

Figure 8: Structure of an analogue quartz watch

Part number	Component	Function
1	Battery	Energy storage
2	Insulator	
3	Positive contact	
4	Negative contact	
5	Printed circuit board	
6	Integrated circuit	Frequency counter, inhibition, motor control
7	Watch quartz	The quartz watch crystal usually has a frequency of 32,768 Hz. Together with the integrated circuit, it forms an oscillator and is therefore the frequency-generating component of the quartz watch.
8	Variable capacitor	The crystal frequency is partially tuned using an adjustable capacitor (only in Figure 8 , right).
9	Coil	The stepper motor, consisting of a coil, stator and rotor, converts the electrical motor pulses into a rotary movement.
10	Coil protection	
11	Stator	
12	Rotor	
13	Gear train	Moves the hands, calendar and other mechanical functions.
14		
15		
16	Gear train bridge	
17	Setting stem	
18	Analogue display	Dial and hands

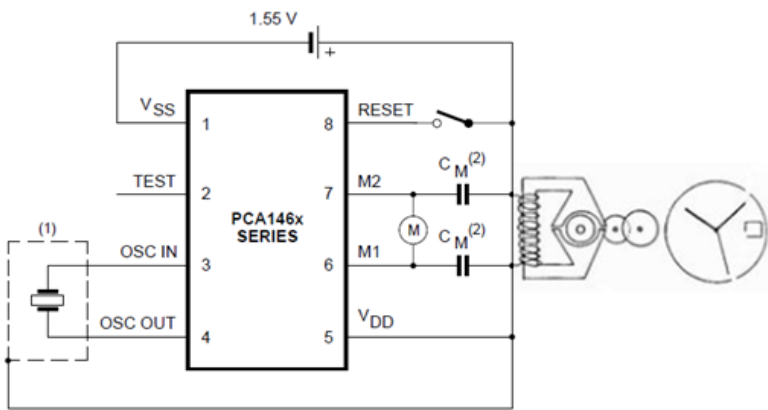

Figure 9: Circuit diagram of an analogue quartz watch

Lavet motor

The most common type of motor in analogue quartz watches is the **Lavet stepper motor**, a single-phase, unidirectional motor. It was invented by the French engineer Marius Lavet and described in 1936.

Structure

The Lavet motor consists of a coil, a coil core, the stator and a rotor.

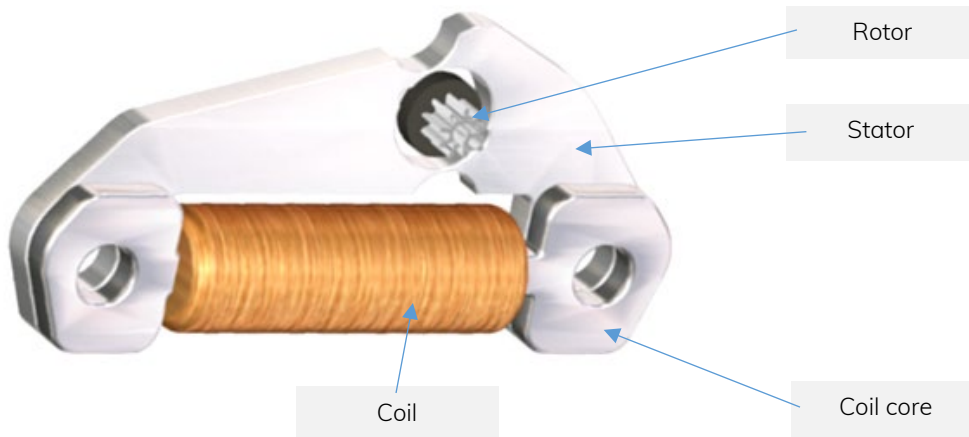

Figure 10: Lavet motor

Like other single-phase stepper motors, the Lavet motor rotates in only one direction, determined by the geometry of the stator.

Control

Lavet motors require short electrical pulses with alternating polarity. The pulse duration depends on the motor design.

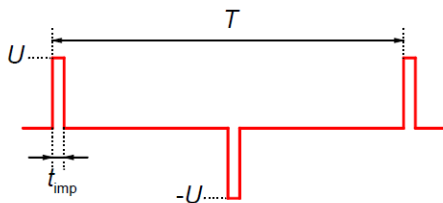

Figure 11 : Voltage of the control of a Lavet motor

The signal shown with the levels $0V$, $+U$ and $-U$ could be generated by a positive and a negative supply voltage. Depending on the battery type, the available supply voltage in a watch movement is either $1.55V$ (silver oxide) or $3V$ (lithium).

An equivalent signal can still be generated by switching the voltage output alternately to the two connections of the motor coil. This function is realised in the watch IC by an H-bridge, allowing polarity reversal with a single supply voltage, thus enabling bidirectional **current** through the coil without a negative voltage rail.

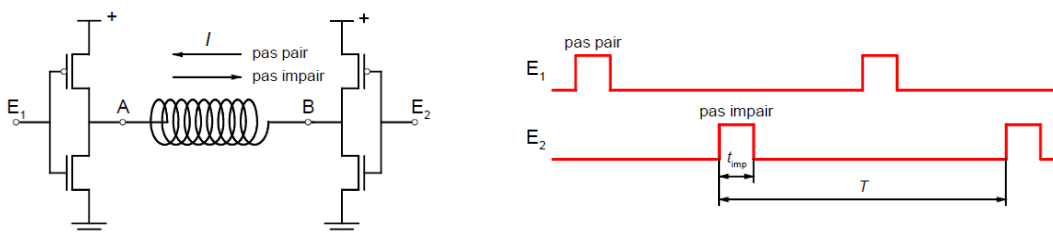

Figure 12: Left: H-bridge and coil for control.

Right: Bipolar output signal.

Coil

The coil consists of fine copper wire insulated with polyurethane, wound around a soft iron core (FeNi). When the coil is energised, it generates a magnetic field that moves the rotor by one step (one half turn). In addition, the movement of the rotor also induces a voltage in the coil, which can be used by the watch IC to recognise whether the step has been carried out correctly.

Parameters		Typical value	Unit	Notes
Wire diameter	d	23	µm	
Wire length	l	30.8	m	
Copper weight		130	mg	
Number of windings	N	6700		
Resistance at 20°C	R ₀	1280	Ω	The resistance varies with the temperature $R_T = R_0[1 + \alpha(T - T_0)]$ R _T Resistance at temperature T R ₀ Resistance at temperature T ₀
Thermal coefficient	α	0.0038	K ⁻¹	
Inductance		1.4	H	

Coil core

The **coil core** bundles and conducts the magnetic field of the coil to the stator. The coil core is made of soft iron due to its high magnetic permeability and low hysteresis losses.

The material of the coil core must have a low magnetic resistance (R_m) and therefore a high magnetic permeability (μ).

The diameter of the coil core is limited so that the entire coil is small. This results in a very high magnetic flux density. The material must allow this without the core becoming magnetically saturated.

The magnetic field of the coil changes direction with each pulse. This results in a hysteresis curve. The hysteresis effect associated with remanence leads to thermal energy losses in the core material.

Stator

The **stator** is also made of soft iron (FeNi). It efficiently conducts the magnetic field of the coil to the rotor. In addition, the stator determines the rest position of the rotor and thus the direction of rotation.

The cross-section of the stator is significantly larger than that of the coil, which reduces the magnetic flux density. This significantly reduces the risk of magnetic saturation.

Modern stators are usually manufactured from a single piece, which reduces production costs and simplifies the assembly of the Lavet motor.

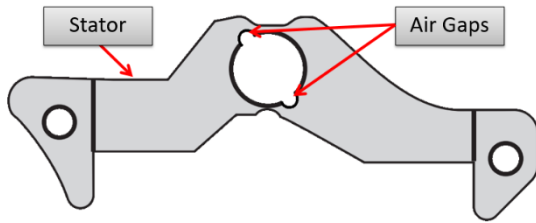

Figure 13: Stator of the Lavet motor

The cogging points of the rotor are decisive for the movement of the Lavet motor and differ depending on whether the coil is energised or not.

Without current flow, the detent points are determined by the arrangement of the air gaps. The rotor aligns itself in such a way that the angle between the poles of the rotor and the main part of the stator is minimised, resulting in a stable rest position.

Rotor

The **rotor** consists of a permanent magnet mounted on a steel pinion, an arbor and a pivot.

If the coil is not energised (between the steps), the rotor aligns itself using the air gaps in the stator and holds the gear train in position.

During a motor step, the coil generates a magnetic field to which the rotor aligns itself. This causes the rotor to turn half a revolution further and transmits the movement to the gear train via the pinion.

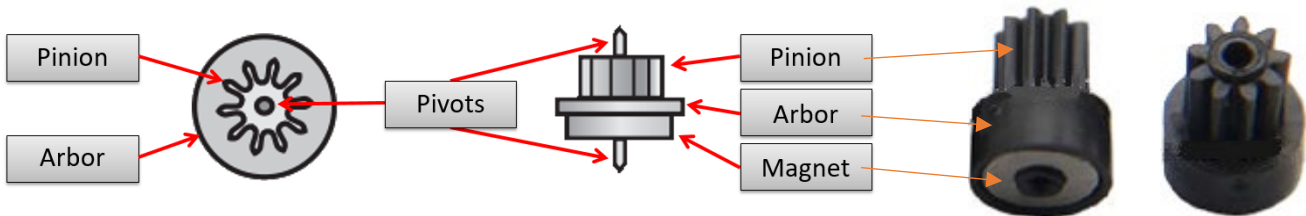

Figure 14: Rotor of the Lavet motor

The rotor is made of a magnetically hard material, typically samarium-cobalt (SmCo₅), which provides high remanence and coercivity, ensuring stable magnetisation over time.

Two properties are particularly important for this:

- a high remanence B_r , therefore the remaining magnetisation after the magnetic field has been removed,
- and a high coercive field strength H_c i.e. resistance to demagnetisation.

These properties ensure that the rotor remains reliably magnetised even under external influences.

Integrated Circuit (IC)

Functions of the IC

The integrated circuit is the central control unit of an analogue quartz watch. It performs several key functions:

- Initiation of quartz oscillation.
- Divide the oscillator frequency down to 1 Hz.
- Compensation of a deviation of the oscillation frequency of the quartz oscillator from the nominal frequency by inhibition.
- Generate the motor pulses.
- Check whether steps have been carried out correctly and trigger correction pulses when a missed step is detected.
- Checking the battery voltage (EOL).
- Operating mode without motor pulses for precise time setting and as a power-saving mode during storage.
- Operating mode with accelerated motor pulses for the tests.
- Additional functions such as chronograph, alarm, etc. may be required.

The following illustration shows a typical circuit for an analogue quartz watch.

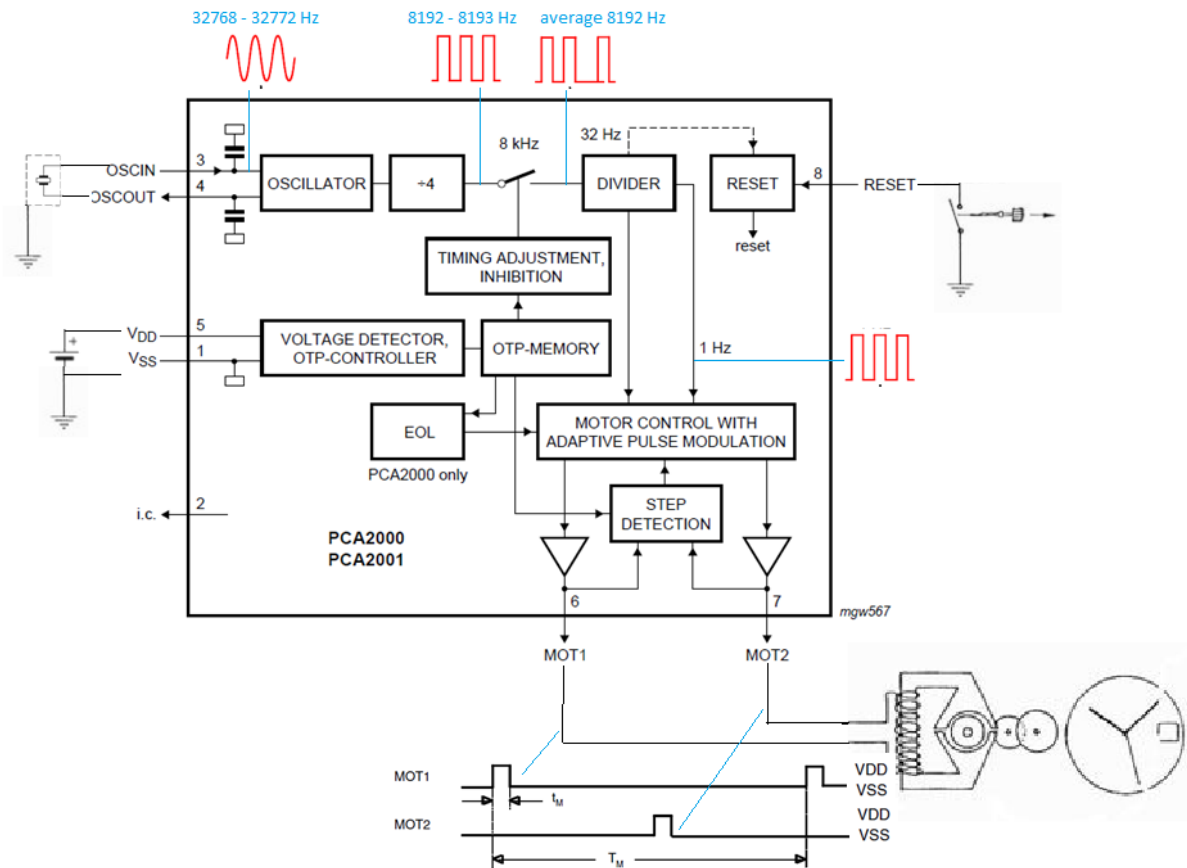

Figure 15: Circuit diagram of the watch IC

In this IC, the load capacitors for the 32.768 Hz crystal resonator are already integrated and are located at pin 3 and pin 4.

The frequency of the crystal resonator is first divided by 4. The reduced frequency can either be divided further or suppressed for a short time - this function is called **inhibition** and is described in detail in the "Inhibition" section.

Step recognition

Step detection occurs after each motor pulse and verifies whether the rotor has completed its half turn or returned to its starting position.

The motor pulse is intentionally short so that the rotor begins to move during the pulse but completes the rotation by inertia after the pulse ends. It then either continues to rotate (correct movement) or falls back to the starting position (no step executed).

The rotor's movement induces a voltage in the coil, which is detected by the watch IC across a resistor (see Figure 16). The test is carried out in four phases (see Figure 17). After a short waiting time in phase 2, an induced voltage with the same polarity as the motor pulse is expected in phase 3. In phase 4, a voltage of opposite polarity must be detected. If these signals are not recognised within 31.25 ms, the step is deemed not to have been executed.

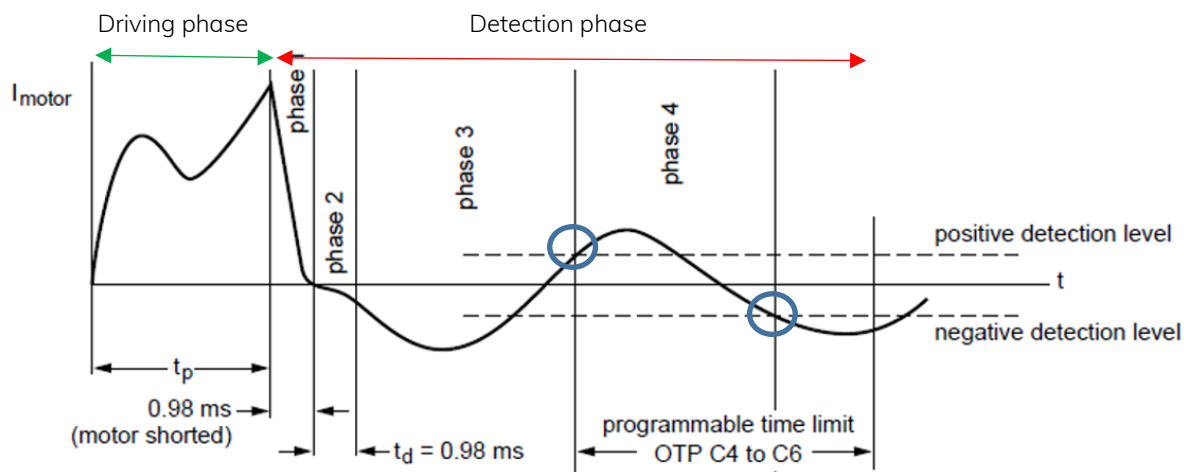

Figure 17: Current curve during and shortly after motor pulse.

Correction sequence

If a missed step is detected, the IC initiates a correction sequence consisting of a short reverse-polarity pulse, followed by a full motor pulse at maximum power level. During the correction sequence, a short pulse with a duration of 0.98 ms and reversed polarity is generated first, followed by a motor pulse at the highest energy level.

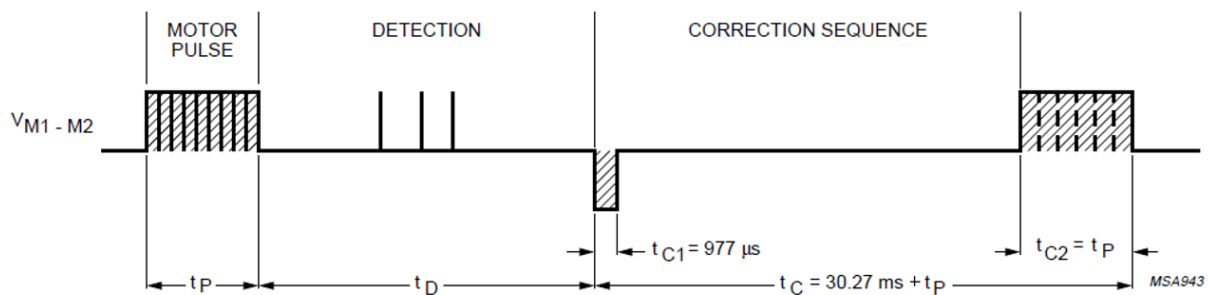

Figure 18: Detection of motor pulse and correction sequence

Energy level adjustment

The adjustment of the energy level begins at a predefined minimum value (e.g. Stage 1 = 56.25%). If a motor step is not executed correctly, the energy level is increased by one stage — each stage representing an increment of 6.25% in the chopping pulse ratio (duty cycle).

If the maximum level is reached (e.g. Stage 8 = 100%), step detection may be disabled by the IC, depending on the design, to prevent further power escalation.

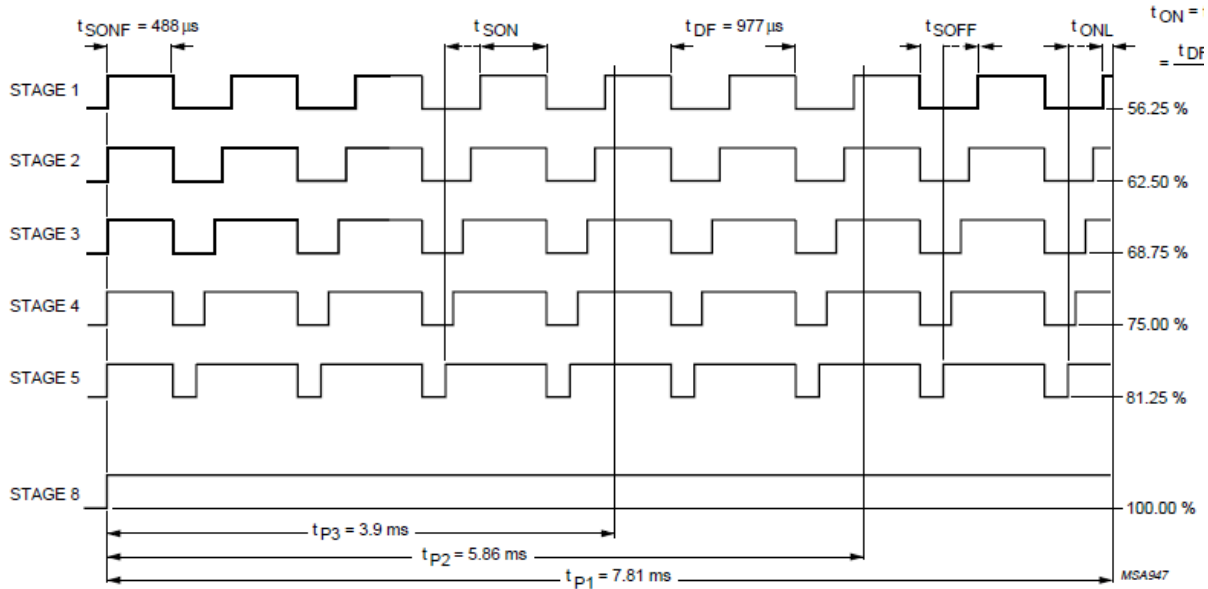

Figure 19: Schematic representation of energy level

The energy level remains constant for 4 or 8 minutes, as long as all steps are completed successfully. It is then reduced by one level and remains at this level as long as no missed steps are detected.

However, if a missed step occurs, a correction sequence is executed, and the energy level is increased by one level.

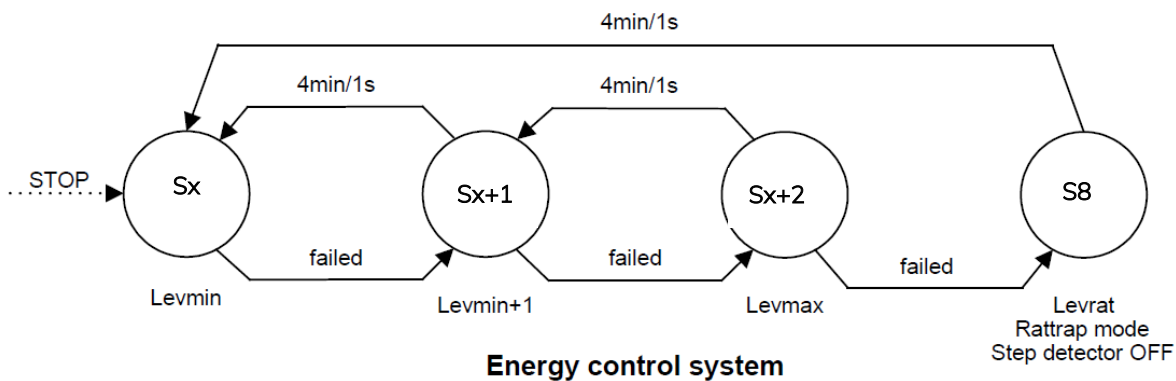

Figure 20: Flowchart of the control of energy levels

Gear train

The gear train of a quartz watch is used to transmit the movement from the Lavet stepper motor to the hands of the watch. It consists of several gears that translate the rotary movement into the corresponding rotation rates for the second, minute and hour hands.

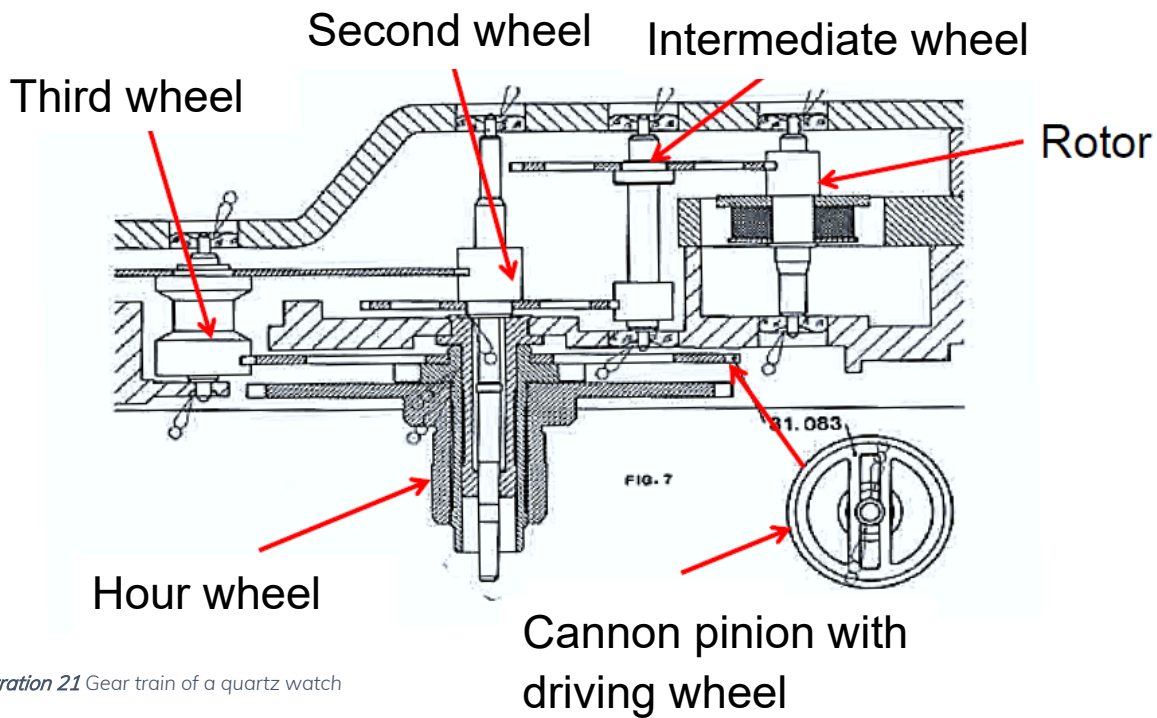

Illustration 21 Gear train of a quartz watch

Structure of the gear train of a quartz watch:

- **Lavet motor rotor** - advances by 180° with each pulse — typically once per second.
- **Second wheel** - Coupled directly or via an intermediate wheel to the rotor of the Lavet motor and rotates once every 60 seconds.
- **Minute wheel** - Reduces the speed of the second wheel to one revolution per hour.
- **Hour wheel** - Reduces the speed further so that it rotates once every 12 hours.
- **Additional wheels** - If a date or weekday display is available, additional wheels drive these functions.

The gear train is designed to work as smoothly as possible in order to minimise energy consumption and ensure even movement of the hands.

In **movements without a second hand**, the Lavet motor usually runs at a lower frequency. There is often one step per minute, causing the minute hand to jump visibly. To make the movement smoother, one step is often performed every 20 seconds.

In this case, the reduction ratio of the Lavet motor to the minute wheel is 1:90.

Digital quartz watch

A digital quartz watch consists of the following main components:

- **Battery** - power supply.
- **Integrated circuit (IC)** - acts as a counter and driver for the display.
- **Quartz crystal** - serves as a time base with a frequency of **32,768 Hz**.
- **Display** - usually a **liquid crystal display (LCD)**, as it is energy-efficient and can be operated with very low currents.

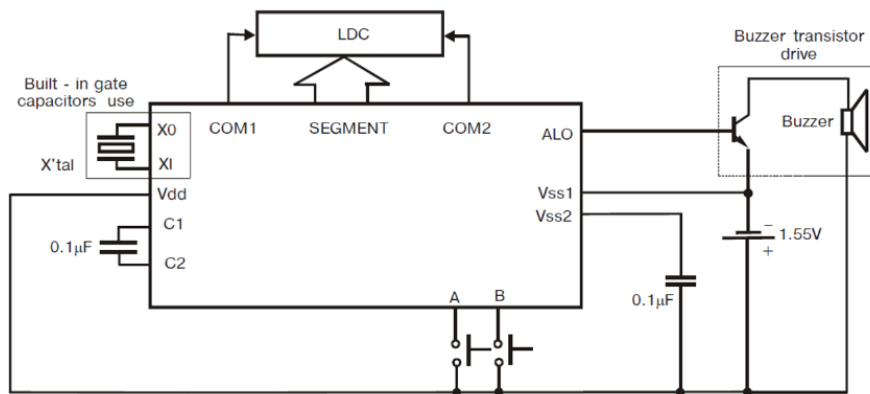

Figure22: Circuit diagram of a digital quartz watch



Figure 23: Left: Electronic representation of hands. Centre: Time display with digits. Right: Combination of hands and digits.

Digital quartz watches usually offer additional functions:

- **Date display** (day, month, year, weekday)
- **Stopwatch** (from milliseconds to several hours)
- **Alarm** (multiple alarms possible)
- **Backlight** (EL panel or LED)
- Countdown **timer**
- **Dual time zone display**
- **Radio-controlled timekeeping** (e.g. DCF77)
- **Solar-powered charging**
- **Smartwatch functions** (e.g. Bluetooth, activity tracking, music control)

Integrated Circuit (IC)

Figure 24 shows a circuit diagram of the DS-A1369A-001 watch IC. The oscillator frequency can be fine-tuned using a trimmer capacitor.

2) Piezo or Speaker Drive Type:

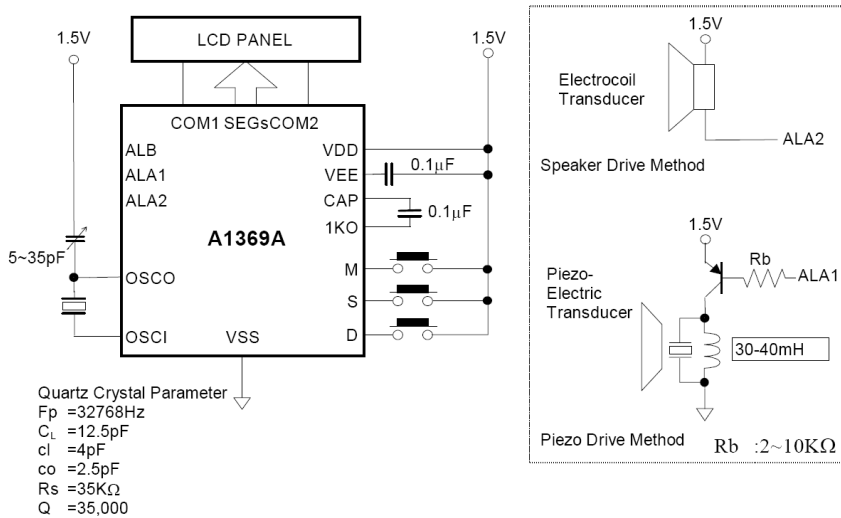

Figure 24: Schematic for a digital quartz watch.

Liquid crystal display (LCD)

Liquid Crystal Displays (LCDs) consist of individual segments, each composed of two polarizing filters with a layer of liquid crystal material in between. The orientation of the liquid crystal molecules, influenced by an applied AC voltage, determines whether light can pass through the segment or not.

In the most common LCD type used in watches, the **twisted nematic (TN)** structure, the two polarizers are arranged at a 90° angle. Without voltage, the liquid crystal molecules form a helical structure that gradually rotates the polarization of incoming light by 90°, allowing it to pass through the second polarizer. The segment appears **bright**.

When a voltage is applied, the molecules align with the electric field, the twist is suppressed, and the polarization is no longer rotated. As a result, light is blocked by the second polarizer, and the segment appears **dark**.

To prevent electrochemical degradation of the display, an **alternating voltage (AC)** is applied. In most digital quartz watches, this AC voltage is directly derived from the quartz oscillator (typically 32,768 Hz). Therefore, measuring the LCD drive frequency provides an indirect method to evaluate the **rate deviation** of the quartz oscillator.

Rate calibration

After assembly, a quartz watch must be calibrated to ensure timekeeping accuracy. Firstly, the frequency of the oscillating quartz crystal is compared with a precise reference. In a second step, a correction is made to ensure the accuracy of the watch.

The frequency correction can be achieved either by adjusting the load capacitance of the quartz oscillator or by electronic compensation within the integrated circuit:

- In direct frequency adjustment, the quartz load capacitance is modified - either via a variable **trimmer capacitor** or by switching in selected fixed capacitors.
- In electronic compensation, a certain number of quartz oscillations are usually periodically omitted in the IC (**inhibition**) in order to correct the effective frequency.

Other methods, such as setting a programmable start value in the counter, also exist, but are less common and are not discussed in detail here.

Variable capacitor

A trimmer capacitor is used to adjust the oscillator frequency to achieve a rate deviation within ± 2.5 s/day.

However, trimmer capacitors tend to drift over time, which may lead to long-term rate deviation. A service centre or trained watchmaker can readjust the watch if needed.

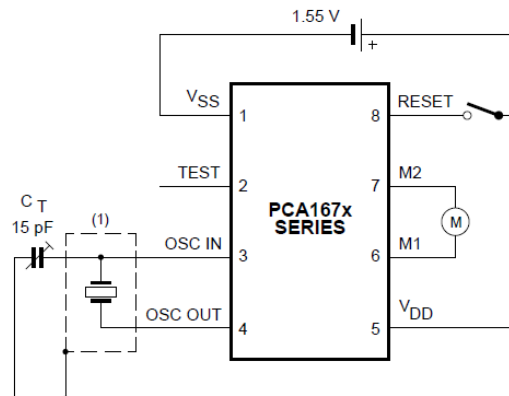
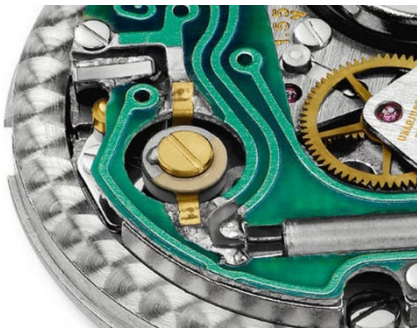

Figure 25: Left: Image of a variable capacitor on a movement. Right: Block diagram of an analogue quartz watch with variable capacitor.

Fixed capacitors

Instead of a trimmer, one or more fixed capacitors can be used to adjust the quartz frequency. This solution offers better long-term stability, though it limits post-assembly adjustments.

As individual adjustment by assembly is time-consuming, a capacitor network with four stepped fixed capacitors is often used in series production. The capacitor network typically consists of four binary-weighted capacitors. Connections to the quartz circuit can be selectively opened (e.g. by laser trimming) or closed using solder bridges, allowing 16 discrete frequency steps.

Temperature-related frequency deviations can be partially compensated by using thermally compensated ceramic capacitors (e.g. thermally compensated ceramic capacitors with parabolic characteristics).

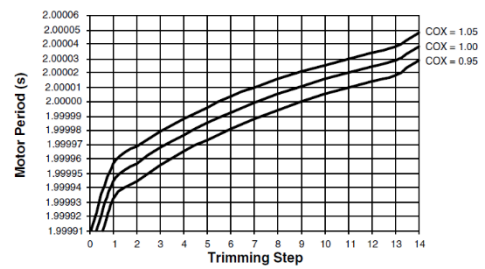
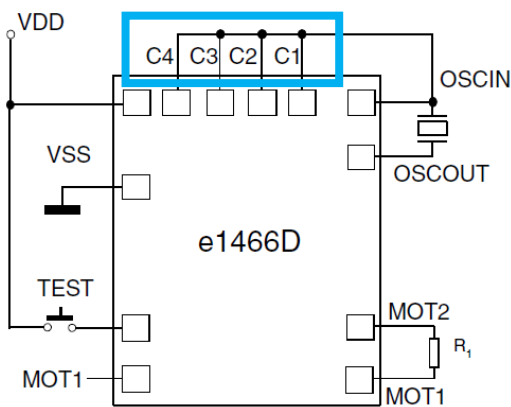

COX means frequency deviation due to production process variations.

Trimming inputs C1 ... C4 are binary weighted, i.e.,

C1 ... C4 = 0 corresponds to trimming step 0
 C1 ... C4 = 1 corresponds to trimming step 15

LSB = C1



Figure 26: Image of the circuit board with watch IC and adjustment by connecting integrated fixed capacitors via solder bridges.

Inhibition

Instead of directly correcting the oscillation frequency, the watch IC can compensate for the deviation electronically.

In the most common method, the quartz frequency is deliberately set slightly too high (e.g. between 32,768 Hz and 32,771 Hz). To compensate for the resulting rate deviation, a programmable number of oscillation pulses are periodically suppressed before the signal reaches the frequency divider, effectively slowing the watch.

This method is called inhibition. Figure 27 shows the function blocks of the frequency input, including a switch for suppression at an intermediate frequency of approx. 8 kHz.

Whether the input frequency is divided before inhibition (and if so, by what factor) is specified in the data sheet of the respective watch IC. The period duration of the correction also depends on the IC. Typical values are 60 or 120 seconds, but other correction periods are also possible.

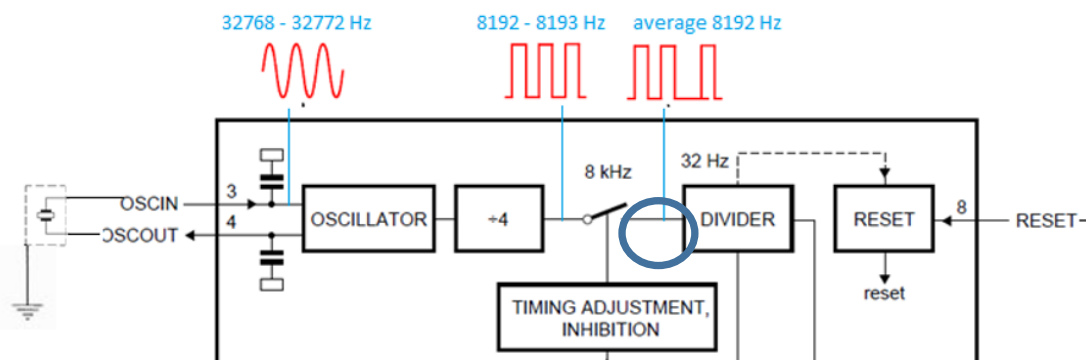

Figure 27: Function blocks in the watch IC at the input of the oscillation frequency

The PCA2000 watch IC serves as an example for calculating inhibition-based frequency compensation. In this configuration, 5.2 pF capacitors are connected to the quartz crystal, which is below the specified load capacitance (CL) of 8.2 pF.

This reduced capacitive load causes the quartz to oscillate approximately 60 ppm faster, resulting in a rate gain of about +5.18 seconds per day, based on the nominal frequency of 32,768 Hz.

Before compensation, the actual frequency deviation is individually measured. The excessive frequency is then corrected by the IC through **inhibition**, that is, by **periodically suppressing a programmable number of oscillation pulses** before they reach the frequency divider.

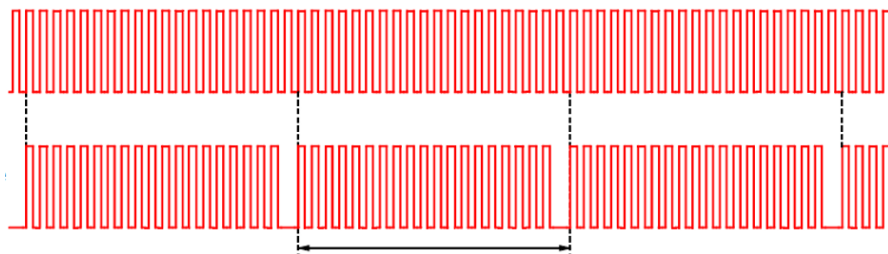

Figure 28: Illustration of the 8 kHz frequency before and after inhibition

If the inhibition is performed once per minute, each removed oscillation results in a slowdown of

$$\varepsilon_1 = \frac{1}{F_p \cdot T_p}$$

with F_p as the frequency before inhibition and T_p the duration between two inhibitions.

As an example, $F_p = 8192 \text{ Hz}$ and $T_p = 60 \text{ s}$ result in a slowdown of

$$\varepsilon_1 = \frac{1}{F_p \cdot T_p} = \frac{1}{8192 \cdot 60} = 2.03 \cdot 10^{-6} = 2.03 \text{ ppm} \rightarrow 0.176 \text{ s/d}$$

Suppressing N oscillations results in a slowdown of

$$\varepsilon_N = N \cdot \varepsilon_1 = \frac{N}{F_p \cdot T_p}$$

This information is also documented in the PCA2000 data sheet, as shown in Figure 29.

Table 4. Time calibration

Calibration period	Correction per step (n = 1)		Correction per step (n = 127)	
	ppm	seconds per day	ppm	seconds per day
1 minute	2.03	0.176	258	22.3
2 minutes	1.017	0.088	129	11.15

Table 5. Words and bits

Word	Bit							
	1	2	3	4	5	6	7	8
A	number of 8 192 Hz pulses to be removed							calibration period

Bit	Value	Description
Inhibition time		
1 to 7	-	adjust the number of the 8 192 Hz pulses to be removed; bit 1 is the MSB and bit 7 is the LSB
Calibration period		
8	0	1 minute
	1	2 minutes

Figure 29: Description of the register for inhibition control in the PCA2000 data sheet.

This example is now used to calculate the correction value that is written to register A. It is assumed that the measured frequency deviation of the quartz crystal is $R_s = 5.18 \text{ s/d}$ and the desired deviation at room temperature is $R_t = 0.2 \text{ s/d}$.

As mentioned in the section on the watch quartz, a slightly positive rate is often sought in order to compensate for the temperature influence on the wrist.

With one inhibition every minute, the number of oscillations to be suppressed is calculated as follows

$$N = \frac{R_s - R_t}{\varepsilon_1} = \frac{5.18 \text{ s/d} - 0.20 \text{ s/d}}{0.176 \text{ s/d}} = 28.295.$$

The next integer written to the register is 28. The rate after adjustment is therefore

$$R_r = R_s - (n \cdot \varepsilon_1) = 5.18 - (28 \cdot 0.176) = 0.252 \text{ s/d}.$$

In practice, the inhibition value can be programmed either via the **manufacturer's programming tools** or by using **Witschi instruments** such as the **Analyzer Q2** or **QuartzMaster® QC**.

Measurements and tests

The common test methods are described in detail in the following chapter.

Battery voltage

The voltage of a watch battery remains almost constant during most of its service life, then drops sharply shortly before complete discharge.

Measuring the voltage (even under load) only indicates whether the battery is still usable or already depleted. An exact statement about the remaining capacity is not possible in this way.

By applying a defined resistance, it is possible to check whether the battery can supply the required current without the voltage dropping to an unacceptable level.

In addition, the water resistance should also be checked during each test. White deposits or residue around the gasket may indicate electrolyte leakage. In such cases, the battery should be replaced even if the voltage appears normal.

For the measurement, the positive terminal is placed on the contact surface and the negative terminal is connected to the test probe (usually the black clip). Depending on the device, different load values can be set to realistically assess the battery condition.

Designation	Load	Meaning
No Load (B0)	2 M Ω	simulates IC-only load (almost without power consumption)
Low Drain (BL)	2 k Ω	simulates normal motor activity
High Drain (BH)	100 Ω	simulates peak demand (e.g. alarm or backlight)

In the "Low Drain" test, a load of 2 k Ω is activated every second for 10 ms and the voltage is measured - either continuously or for 5 seconds.

In the "High Drain" test, a load of 100 Ω is applied once for 500 ms (with the Q1 analyser: 1000 ms) to test the voltage under high load.



Figure 30: Battery voltage measurement without load, with low load and high load.

As the procedure does not allow any statement to be made about the remaining capacity, battery replacement is recommended at every service as a precaution.

Certain voltage limits apply to determine whether a battery is fully discharged.

Battery type	Load	Battery discharged	Battery good
Silver oxide	No Load	< 1.4 V	1.45 to 1.6 V
	Low Drain	< 1.4 V	1.45 to 1.6 V
	High Drain	< 1.2 V	>1.25 V
Alkaline (large watches)	High Drain	< 1.2 V	1.4 to 1.6 V
Lithium [1]	No Load	< 2.8 V	2.9 to 3.2 V
	Low Drain	< 2.8 V	2.9 to 3.2 V

[1] Lithium batteries are available in a variety of technologies with different voltages and limit values.

Current measurement

The current consumption of a quartz watch is a key quality parameter, as it directly affects battery life.

IC current (CI): In analogue quartz watches, a low current is permanently consumed by the integrated circuit (IC).

Total current (CT): During the motor pulses, a significantly higher current consumption is briefly added. The sum of IC current and motor current is the total current.

Witschi measuring devices record this by means of an integrating measurement, whereby the average total current over the measuring period is indicated.

Modern test instruments can automatically differentiate between IC and motor-related current components and display both values simultaneously.

In addition, a current-saving mode can be activated on many watches by pulling the hand setting shaft. In this mode, the IC remains active, but no motor pulses are executed. The IC current can also be tested in this mode.

The manufacturer's tolerance specifications are binding for the assessment of the current consumption.

Typical CT values for analogue quartz watches:

- with second display: approx. **0.7-1.2 µA**
- with longer pulse period (without second hand): approx. **0.5-0.7 µA**

These values serve as a guideline for normal current consumption. Elevated current readings may indicate mechanical resistance (e.g. sticky gear train), misaligned hands, or electrical faults such as partial coil shorting.

Increased current consumption causes the battery to discharge more quickly. For ICs with adaptive motor pulses (asservissement) in particular, this is an indication of possible faults such as

- a gear train that does not move smoothly,
- Hands that touch lightly and therefore require more force,
- a coil with damaged insulation, which results in increased power loss and higher current draw.

In such cases, targeted troubleshooting should be carried out in order to reduce power consumption and prevent premature battery discharge.



Figure 31: Current consumption of a quartz watch. Total current (CT) and IC current (CI)

Minimum operating voltage

The **minimum operating voltage (MV)** indicates how reliably a quartz watch continues to function when the battery is nearly depleted or under electrical load. It indicates the remaining operating margin of the movement as the battery voltage drops.

To determine this value, the supply voltage is gradually reduced while observing the hand movement using a test mirror or optical sensor. Once the hands stop, the voltage is slowly increased again until movement resumes. The voltage at which the hands restart is recorded as the **minimum operating voltage**.

In practice, it is often sufficient to verify whether the watch continues to operate correctly at a predefined reduced voltage. For quartz movements powered by silver oxide batteries, the **typical minimum operating voltage** is approximately **1.2 V**.

EOL Voltage (End-of-Life Indication)

Many quartz watches feature an **End-of-Life (EOL)** function that provides a visual warning when the battery is approaching depletion.

To test this function, the supply voltage is gradually lowered until the movement enters End-of-Life (EOL) mode. This typically occurs at around **1.25 V** for movements powered by silver oxide batteries.

In EOL mode, the stepper motor performs a burst of **four rapid steps** every **four seconds**, causing the second hand to move in 4-second jumps rather than once per second. This characteristic stepping pattern signals to the wearer that the battery needs to be replaced.

It is important to note that **the EOL trigger is not checked continuously**. In most movements, the battery voltage is monitored only once per minute. As a result, there may be a delay of up to 60 seconds before the stepping behaviour changes after the voltage drops below the threshold.

Some modern ICs include a **fast test mode** in which the EOL detection operates in accelerated cycles. This allows technicians to verify EOL behaviour more quickly, as the system reacts immediately to voltage changes and increases the stepping frequency as soon as the threshold is crossed.

Rate deviation

The **rate deviation** refers to how much a quartz watch gains or loses compared to a precise reference. It is usually expressed in **seconds per day (s/d)** or **parts per million (ppm)**.

Witschi measuring devices use highly stable internal oscillators (OCXO or TCXO) to provide the reference signal. The measured deviation is based on time intervals between motor pulses or quartz oscillations.

Two types of rate deviation are commonly distinguished:

- **Motor rate deviation (RM):** This value reflects the actual stepping behaviour of the motor and corresponds to the real movement of the hands. It is the relevant metric for evaluating the timekeeping accuracy as perceived by the user.
- **Quartz rate deviation (RQ):** This value is based on the raw frequency of the quartz crystal, independent of any correction mechanism such as inhibition. It reflects the intrinsic stability of the oscillator.

For meaningful results, the **measurement duration** must be carefully chosen:

- For standard quartz watches, the duration should be a multiple of the motor's stepping interval.
- For watches with **inhibition correction**, it must span at least one full inhibition cycle (e.g. 60 s, 120 s or longer) to obtain a representative average.

If a watch alternates between positive and negative rate deviations in repeated 60-second measurements, this is a strong indication that **inhibition correction is active**. In such cases, the measurement duration should be increased accordingly.

Watches with inhibition correction

In watches with inhibition adjustment, the quartz frequency is not adjusted, but is set slightly above the target frequency in the IC (typically +0.5 to +10 s/d). In order to correct the rate, oscillation pulses are periodically suppressed in the frequency divider - This correction method is known as **inhibition**.

Typical inhibition periods are 60 s or 10 s, with precision watches also 120 s or longer (up to 960 s). During the inhibition cycle, the watch gains slightly; in the inhibition moment, it is strongly corrected backwards

If the measurement duration of such watches is too short, regular fluctuations in the result may occur. If a watch shows alternating positive and negative deviations over a measurement period of 60 s, it is highly probable that an inhibition watch is present. In this case, the measurement duration should be adjusted to the inhibition period.

Temperature influence

The rate deviation of quartz watches depends on the temperature of the watch. It is therefore important that the watch is at normal room temperature (~ 23°C) during the measurement. Comparative measurements must be carried out at the same temperature.

The measurement accuracy of the QuartzMaster® is unaffected by ambient temperature fluctuations. However, the watch under test must be at room temperature for valid results.

Typical values for the rate deviation

In the case of watches with inhibition adjustment, the adjustment is usually carried out in steps of 0.18 s/d (in some watches also 0.09 s/d or 0.36 s/d). The adjustment is usually performed in such a way that the rate deviation is as close as possible to 0 but in the positive range.

The deviation due to the ageing of the quartz and the temperature deviation are added to the initial deviation.

A rate deviation of between **-0.1 s/d** and **+0.3 s/d** can therefore be expected for medium-quality quartz watches.

The manufacturer's specifications are binding for the maximum permissible deviations.



Figure 32: Measurement of motor rate deviation (RM), quartz rate deviation (RQ), power level (PL) and pulse duration (PW)
 Left: With QuartzSensor/terminal via an inductive/capacitive sensor. Right: With QuartzMaster@ /Terminal via the current measurement.

Rate deviation quartz

The quartz frequency is determined by detecting periodic current fluctuations at approximately 32,768 Hz. This means that frequency measurement is also possible for watches without motor pulses.

The rate deviation can be determined directly via the quartz frequency for watches whose rate is corrected by capacitor adjustment. In watches with inhibition, on the other hand, the measured quartz frequency does not correspond to the effective timekeeping rate due to periodic inhibition correction.

The frequency can be measured either capacitively, by detecting the electrical field of the quartz, or acoustically, as an ultrasonic wave.

In inhibition-controlled movements, the quartz frequency is not calibrated directly and is usually above +1 s/d.

The indirect determination of the rate from the motor pulses, without taking the inhibition into account, is dealt with in the chapter "rate deviation".

Pulse duration

When measuring the current pulses of the stepper motor, the motor pulses can also be analysed in addition to the rate deviation. Both the **pulse duration (PW)** and the **power level (PL)** can be measured and analysed. The pulse duration describes the length of the motor pulse and is usually already set at the factory.

Power level

Two types of motor pulses are used in analogue quartz watches:

- **Fixed pulse:** The battery voltage is constantly applied to the motor coil for the entire pulse duration.
- **Chopping pulse:** The voltage at the motor coil is switched on and off quickly at a fixed frequency (usually 1 kHz) during the pulse duration.

With the chopping pulse, the energy supplied to the coil can be controlled via the ratio of on/off time (the chopping ratio). This allows the energy consumption to be flexibly adapted to the requirements of the movement.

In watches with **adaptive motor pulses**, the movement automatically determines the minimum pulse energy required for reliable step operation. The chopping ratio (power level) - and in some cases also the pulse duration - can be adapted to the current power requirement in several stages, which can also be measured in the current consumption.

These watches have a step monitor that recognises whether the motor has performed the step correctly. If a step does not occur, a second pulse is sent at the maximum energy level (fixed pulse).

During normal operation, the power level is automatically reduced by one step (e.g. every 4 minutes) as long as all motor steps are executed correctly. If a missed step is detected, the watch immediately increases the power level to restore reliable motor operation.

Measuring the current **power level** can therefore give an indication of the condition of the movement.

Power consumption increases in the event of vibrations, date changes, falling battery voltage or mechanical problems (e.g. sluggish gears). After a fault, it may take several minutes for the power level to stabilise back to the original level.

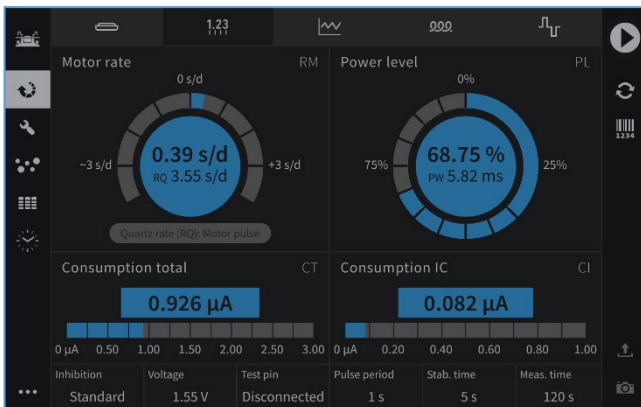

Figure 33: Measurement of pulse duration (PW) and power level (PL)

Motor Pulse Profile

The **pulse shape** shows the current consumption over time during a motor pulse and provides diagnostic insight into the mechanical and electrical behaviour of the movement.

In a normally functioning watch, the current rises continuously at the start of the pulse, reaches a maximum, falls slightly and rises again shortly before the end of the pulse.

In the event of a mechanical blockage, the current increases continuously up to the maximum value and remains constant there until the end of the pulse - an indication of increased resistance in the gear train or blocked hands.

A significant asymmetry between the positive and negative pulse amplitudes may indicate a motor defect, such as a faulty coil or magnetic imbalance.

Each pulse is recorded individually and displayed as an oscillogram, with alternating positive and negative pulses visible. This enables a detailed analysis of the pulse shape and targeted troubleshooting.



Figure 34: Left: good watch with chopping pulses. Right: bad watch with chopping pulses.



Figure 35: Left: good watch without chopping pulse. Right: Bad watch without chopping pulse.

Resistance measurement

Coil resistance measurement is used to detect interruptions or short circuits in the motor coil of analogue watches as well as insulation faults between the coil, coil core or circuit board. It is also useful for continuity and insulation testing of conductors, connections and switches.

The resistance measurement is carried out at a very low voltage so that there is no danger to the watch and the protective diodes in the IC do not influence the measurement.

Coil resistance

Before performing resistance measurements, the battery must be removed from the watch. The two connection points of the coil are contacted with the movable contact clamps or test probes - the polarity is irrelevant. If the measuring points are not clearly recognisable, it is advisable to consult the data sheet of the respective watch calibre.

The typical **coil resistance** of analogue quartz watches is between **1 and 3 k Ω** . For exact values, please refer to the technical specifications of the watch calibre.

- An interruption in the coil appears as a very high resistance or "open".
- A winding short circuit (short circuit of individual windings) leads to a significantly reduced resistance value.

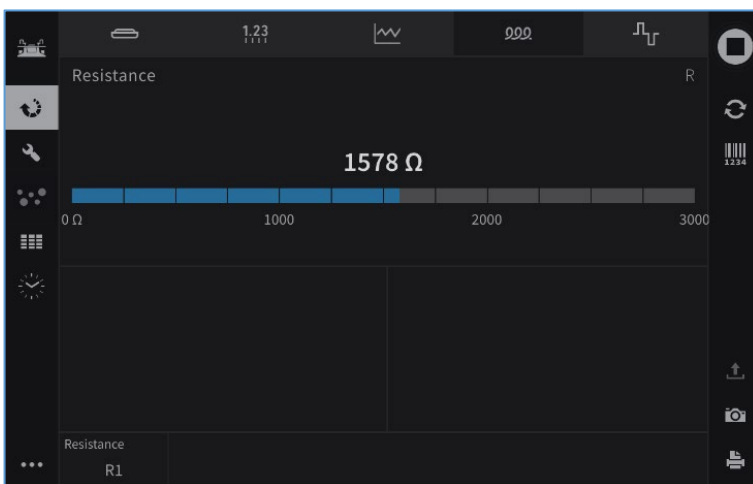

Figure 36: Coil resistance measurement with QuartzMaster® and Terminal.

Coil insulation

To test the **insulation** between the coil and the circuit board, use the contact clamps or test probes to contact a connection point on the coil and the movement circuit board.

The measured resistance value is displayed numerically.

The insulation is considered sufficient if the measured resistance exceeds 1 M Ω . Lower values may indicate insulation faults.

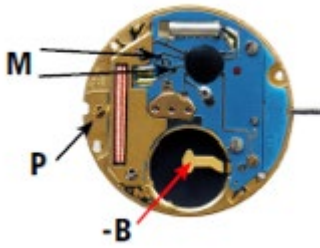

Figure 37: Connections M for measuring the coil.

BATTERY		✓	MOVEMENT		✓
Batt. voltage no load	B0	1.60 V	Min. voltage	MV	OK
Batt. voltage low load	BL	1.59 V	Acceleration	AC	OK
Batt. voltage heavy load	BH		EOL	EO	1.38 V
			Consumption IC	CI	0.099 µA
			Consumption total	CT	0.899 µA
			Quartz rate	RQ	8.02 s/d
			Motor rate	RM	6.26 s/d
			Pulse width	PW	4.85 ms
			Power level	PL	61.00 %
			Resistance R1	R1	open
			Resistance R2	R2	
			Resistance R3	R3	
			Resistance R4	R4	
DEMO Quartz Complete (DEMO Quartz...)					

Figure 39: Example of a complete measurement protocol:

Min. voltage (MV), acceleration (AC), EOL (EO), current consumption IC (CI), total current consumption (CT), quartz rate (RQ), motor rate (RM), pulse duration (PW), power level (PL)

The measurement log, as shown in Figure 39, is generated automatically by the QuartzMaster in conjunction with the Witschi terminal. The recorded values - including minimum operating voltage, current consumption, rate deviations and motor data - appear directly on the display of the device.

In combination with Wicotrace 360°, this measurement data is also stored in the integrated database. There they can be systematically managed, analysed and exported for later verification. This eliminates the need for manual logging and provides a complete, traceable data record for each tested watch.

Accelerated mode

Many watch calibres have a **test point**, often labelled **R/T**, which is accessible on the electronic module. The acceleration and reset functions can be activated via this test point.

In addition to the normal power supply via the contact clamps, the test point is contacted with the yellow contact clamp:

- Applying a **positive voltage** to the test point triggers a **reset** (motor pulses are suppressed)
- Applying a **negative voltage** activates **accelerated mode**

For specific information, please consult the technical data sheet for the movement in question.

In accelerated mode, the watch takes 16 or 32 steps per second. This makes it possible to observe hand movements in the mirror and quickly recognise mechanical problems such as blocking hands or faults when changing the date.

Pulse generator

The pulse generator can be used to test the stepper motor and the mechanical part of an analogue quartz watch independently of the electronics.

Checking the stepper motor

Due to the accelerated operation, mechanical faults such as grazing hands or problems when changing the date are quickly recognised.

Before **testing** the **stepper motor**, remove the battery and attach the contact clamps to the motor connections (M) provided for this purpose.

- Select the pulse duration and chopping ratio according to the specifications of the watch under test.
For accelerated testing, use a pulse frequency of 16 Hz.
If no technical data is available for the movement, the default settings provided by the instrument usually yield satisfactory results.
- Select a voltage that is approximately 0.2 V below the nominal voltage of the watch battery (e.g. 1.35 V for silver oxide batteries).
This realistically takes into account the voltage loss in the watch IC during the motor pulse.
- Secure the movement in the holder and place it on the glass support of the appliance.
- Contact the two connection points of the coil with the movable contact clamps.
The polarity is not critical for functional testing of the motor.
If the connection points are not obvious, consult the data sheet for the relevant watch calibre.
- Use the test mirror to verify whether the second hand is moving.
- To check the **starting voltage**, gradually reduce the voltage until the second hand stops and then increase it until it starts running again.
The pulse duration and pulse ratio parameters can also be gradually reduced in order to determine the operating limits of the circuit.

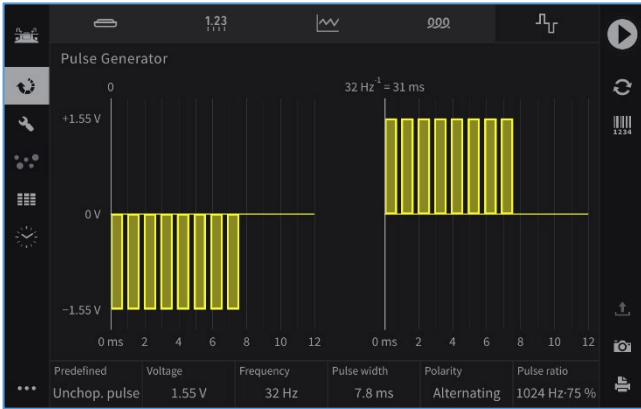

Figure 38: Pulse generator mode when generating motor pulses.

Check buzzer

A permanent signal can be generated to test a piezo buzzer. The piezo should then emit an audible signal.



Figure 39: Pulse generator mode when generating a piezo signal.

Several of the tests described can be performed without opening the watch, using appropriate test equipment.

Testing of closed quartz watches



Figure 42: QuartzSensor with Terminal
Compact and ergonomic measuring device for quartz watches and movements with inserted battery.

Quartz watches should not be opened unless necessary, as this entails the risk of dust or moisture ingress. On some models, it is even possible to change the battery without opening the case - in some cases, the case cannot be opened without causing damage.

Various tests can also be carried out when the watch is closed, allowing the condition of the watch to be assessed.

The **quartz frequency** can also be measured **when the watch is closed** - either with a capacitive or an acoustic transducer. In this case, the oscillation at approx. 32,768 Hz is compared directly with a reference frequency.

In watches with a liquid crystal display (LCD), the capacitive sensor can also measure the switching frequency of the display, which is usually directly coupled to the quartz frequency.

In analogue quartz watches, the motor pulses can be recorded using an inductive pick-up. This enables **rate measurement** with and without inhibition, as well as measurement of the **pulse duration** and the current **power level** - and thus allows a targeted assessment of the movement status.

Induced movement of the hands

If the IC applies at an elevated power level, this may indicate increased mechanical resistance in the gear train, for example due to gumming.

An **externally generated rotating magnetic field** can induce continuous hand rotation even when the watch is closed. This accelerated movement can help to loosen gumming and make the gear train run smoothly again.

*Note: The **Witschi Cyclonic** appliance previously used for this purpose is no longer available in the current appliance programme.*

However, if it is possible and necessary to open the watch, a more detailed inspection can be carried out.

Testing of opened quartz watches

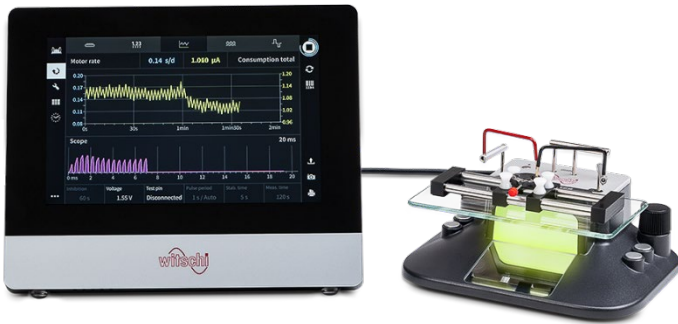

*Figure 43: QuartzMaster® with Terminal
Compact and ergonomic measuring device for open quartz watches / quartz movements.*

When quartz watches are open, all measurements can be carried out with the QuartzMaster as described in the chapter "Measurements and tests".

It is recommended to measure the current consumption every time the battery is changed. This allows you to recognise possible problems in the movement that could have led to a shorter battery life.

Test procedure

[1] Visual inspection

- Check the area between the crown and housing for dirt or deposits.
- Ensure that the hands move freely and do not graze.
- Verify the calendar function (e.g. date change occurs at midnight).
- Check the gear train for dirt or foreign particles.

[2] Testing coil resistance and coil insulation

- Remove the battery. Check coil resistance and coil insulation.
- If values are out of tolerance: Change the movement. Otherwise continue with [3].

[3] Current consumption and rate measurement

- Place the movement above the mirror and connect the Supply+ (red) and Supply- (black) test probes.
- Measure current consumption and rate deviation.
- If a value is outside the tolerance, the movement should be replaced. If the values are normal: continue with step [4].

[4] Check minimum voltage

- Place the movement above the mirror and connect the Supply+, Supply- and RT/T (yellow) test probes.
- Reduce voltage gradually until no more motor steps occur
- Out of tolerance: Replace movement.
Within tolerance: Reinsert the battery and reassemble the watch.

Troubleshooting

Procedure for a non-functioning analogue quartz watch

- Check whether the crown (setting stem) is pulled — motor pulses are inactive in this position.
- Check hand spacing and distance to glass/dial
- Open watch and check reset
- Check the movement for dirt, dust or abrasion, especially the gear train and rotor
- Measure battery voltage
- Check current consumption; if the value is too high, measure → coil resistance
- Check function of gear train, motor and rotor
- Check other functions and components

Defect	Cause	Measure
watch stops	Battery discharged	⇒ Change battery If the battery discharges prematurely: (a) Check current consumption. Check coil resistance (b) Check whether the contact tongue for the negative connection is touching the circuit board and causing a short circuit.
	Expansion spring Hour wheel jammed	In certain movement designs, the hour wheel is held in position under the dial by an expansion spring. If the expansion spring is damaged during assembly or accidentally inserted twice, the required clearance of the hour wheel is reduced. This can lead to a blockage and thus to the movement coming to a standstill.
	Damaged gear wheel	Before fitting the dial and hands, ensure that the hour wheel is correctly aligned with the minute wheel pivot. Excessive pressure can damage the hour wheel when fitting the hour and minute hands. It is therefore necessary to carefully check the force applied when fitting the hands.
	Excessive greasing of the housing tube	It is common practice to apply grease to the case tube to prevent water from entering the watch. However, excess grease can enter the inside of the watch when the stem is fitted and cause malfunctions. It is therefore important to apply the grease precisely and sparingly.
	Problems with the actuating shaft	Adhesive on the square or an actuating shaft that has been cut too short usually occurs when cutting the actuating shaft to size and attaching the crown. In practice, the following symptom is often observed during inspection: "The hands are already moving even though the setting stem is still in its normal (inserted) position." When curing the adhesive, care must be taken to ensure that the setting stem remains correctly aligned in order to avoid adhesive in functionally relevant areas. When shortening the adjusting shaft, ensure that it is long enough and that the square is intact.
	Dust and abrasion	Dust particles, textile fibres or abrasion can get stuck between the wheels and pinions and cause the watch to stop.
	Hand clearance	Check the distance between the hands carefully and adjust it if the hands touch each other. Take particular care to ensure that the counterweight of the second hand does not touch or touch the minute hand.

Watch shows a delay	Insufficient Hand clearance / Stripe second hand on glass	<p>Watches that lag are often caused by insufficient spacing between the hands. It is not only important to ensure the distance between the dial and the hour hand and between the hour and minute hands, but also the distance between the second hand and the crystal and between the counterweight of the second hand and the minute hand.</p> <p>In some cases, the watch works perfectly outside the case, but stops after being inserted into the case. This often indicates that the second hand is touching the crystal.</p> <p>Tip: A small drop of oil on the tip of the second hand can help to recognise whether there is contact with the glass during assembly.</p>
date do not switch	Adhesive on the back of the dial / Date Switching finger damaged	<p>Adhesive residue on the back of the dial can rub against the date or day disc and cause it to come to a standstill.</p> <p>The date disc has an internal tothing into which the switching finger of the date switching wheel engages and advances the disc by one division every 24 hours.</p> <p>Damage to the switching finger or the date disc often occurs if the hand is turned backwards while the switching finger is engaged with the internal teeth.</p>
Incorrect date change	Incorrect AM/PM setting	<p>For movements with a day and date display, the setting shaft must be turned until the day and date change. Only then may the hands be mounted so that the change can take place at the correct time.</p> <p>The wearer must also be informed of how to set the day and date correctly so that the change takes place at 12 midnight.</p>
Gap between housing base and housing	Plastic tool holder not positioned correctly	<p>An incorrectly fastened case back can cause a gap between the case back and the case and thus impair the water resistance of the watch.</p> <p>Before inserting the case back, the position of the recess in the plastic movement holder must be correctly aligned with the setting stem. If this alignment is not carried out, the plastic holder will sit on the setting shaft, causing a gap between the case back and the case.</p>
Dust beneath the crystal	Improper cleaning	<p>To avoid dust and textile fibres, it is recommended that a protective cover or ideally a laminar flow is fitted over the assembly workstation where the casing is carried out. This prevents dust from settling on the workbench or the watch case.</p> <p>Only vacuum pens should be used to clean dials and crystals, as they reliably remove dust. Compressed air pens, on the other hand, only move dust from one place to another and are therefore not suitable.</p>
Ingress of moisture	Leakage: Glass / crown / case back	<p>In such cases, all seals must be replaced.</p> <p>The crown seal can become twisted or damaged during assembly. Therefore, lubricate the housing tube with silicone grease so that the crown can be screwed in and out easily.</p> <p>When opening the case back, use a suitable tool to avoid damaging the seal. The bottom seal should be treated with silicone grease and replaced each time it is opened.</p>

Overview Witschi measuring devices for quartz watches

Function	Q-Test 6000	New Tech Handy	Analyzer Q1	Analyzer Q2	Analyzer Twin	CS1 (G2) with Quartz micro.	Quartz Master	Quartz Sensor
Rate Measurement quartz								
by capacitive transducer	✓	✓	✓	✓	✓	✓	-	✓
by acoustic transducer	✓	✓	✓	-	✓	-	-	-
by current consumption	✓	✓	✓	✓	✓	-	✓	-
Rate measurement								
by inductive sensors	✓	✓	✓	-	✓	✓	-	✓
by capacitive sensors (LCD)	✓	✓	✓	✓	✓	✓	-	✓
by current consumption	✓	✓	✓	✓	✓	-	✓	-
Measurement of current consumption	✓	✓	✓	✓	✓	-	✓	-
Battery tester	✓	✓	✓	✓	✓	-	✓	-
Resistance measurement	✓	✓	✓	✓	✓	-	✓	-
Pulse generator	✓	-	✓	✓	✓	-	✓	-
Analysing the motor pulse	-	-	✓	✓	✓	✓	✓	✓
Adjustment of inhibition watches for selected ICs	✓	-	-	✓	-	-	-	-
Automated test sequences	-	-	-	✓	-	-	✓	✓
Measurement of tuning fork watches	✓	-	-	-	-	✓	-	✓
Measurement of mechanical watches	-	-	✓	-	✓	✓	-	-

Imprint

Publisher

Witschi Electronic AG
Bahnhofstrasse 26
CH-3294 Büren an der Aare
Switzerland
www.witschi.com

Contact

Phone: +41 32 352 05 00
Email: info@witschi.com

Responsible for content

Witschi Electronic AG, Product Management & Training

Copyright and usage rights

© Witschi Electronic AG, Büren an der Aare, Switzerland.

Reproduction of this document, in whole or in part, is **explicitly permitted**, provided that **Witschi Electronic AG** is clearly acknowledged as the source. The content may be used for educational and non-commercial purposes without prior approval.

Any modification, translation, or commercial use requires prior written consent from Witschi Electronic AG.

Disclaimer

All information in this document has been compiled with great care.

Witschi Electronic AG accepts no liability for errors or omissions, or for damages resulting from the use of this material.

Specifications and product features are subject to change without notice.

Document version

D40e | 18.11.2025